

Metal Gear Solid: The Twin Snakes FAQ/Walkthrough (w/ Toy Commander)

by Michael Tincher

Updated to v1.0 on Jun 15, 2004

Metal Gear Solid: The Twin Snakes

GameCube (GCN)

////////////////////////////////////

Written by: MTincher (Michael Tincher) &
Reformed Pirate (Martin Dale-Hench)

Type of FAQ: FAQ/Walkthrough

E-mail address: mtincher69@yahoo.com
hockeyfox@ameritech.net

Version: 1.0

Last Update: June 15, 2004

(_____)
	=====	
	Table of Contents	
	=====	

- I. Introduction
 - a. Authors' Notes
 - b. Copyright
 - c. Site Permission List
 - d. What's New

- II. Basics
 - a. Controls
 - b. CODEC

- III. Walkthrough
 - a. Infiltrating Shadow Moses
 - b. The Hangar and Mr. Revolver
 - c. The Tank and the 'Warehouse to the North'
 - d. Nuke Building and Ninja's Massacre
 - e. Meryl in her Panties! And Psycho Mantis, of course
 - f. The Showdown with Sniper Wolf
 - g. Torture!
 - h. First Encounter with the Twin
 - i. Sweet Revenge
 - j. Quote the Raven, Nevermore!
 - k. Time to Kick It in Gear
 - l. Snake vs. Snake

- IV. Spoiler-Free Guide

- V. Plot Guide
- VI. Weapons/Items
 - a. Items
 - b. Weapons
- VII. Dog Tags
 - a. Very Easy
 - b. Easy
 - c. Normal
 - d. Hard
 - e. Extreme
- VIII. Bosses
- IX. Ghost Pictures
- X. Endings
 - a. Meryl's Ending
 - b. Otacon's Ending
 - c. Similarities
- XI. Secrets
- XII. FAQ
- XIII. Closing

()	()
		=====			
		I. Introduction			
		=====			

```
=====
A)                               == Authors' Notes ==
=====
```

MTincher

Hello everyone! I'm Michael Tincher, and I didn't do anything in this FAQ. I held Winnie at gun point and made him write everything, and say it was co-authored. You think I'm kidding?! Well, you are write.

In this FAQ/Walkthrough for Metal Gear Solid: The Twin Snakes, I will lend you my assistance throughout the second disc. The appendices I wrote for include the following: Dog Tags ; Characters ; Endings ; and the Spoiler-Free Guide. So, if you have any questions that are held within those sections, drop an e-mail my way.

Also Martin, thanks for the pleasure. You pervs, I meant the pleasure of being a wonderful co-author.

Hi, this is winnie the poop, A.K.A. Fox, A.K.A Reformed Pirate, A.K.A. that jackass in the corner that won't stop saying A.K.A. I am privileged to co-author with MTincher, an above-average writer, for a legendary game such as Metal Gear Solid. Although there are a dozens of excellent FAQs out for this very game, we have decided to make a FAQ for this because... just because! However, we have tried to make this FAQ a bit more unique than a standard FAQ. We have incorporated some maps in our walkthrough and we plan to add a detailed Plot Guide along with it.

Metal Gear Solid is originally a product of Hideo Kojima and Konami, but the guys at Silicon Knights (thanks Adrenaline ;)) has taken the rights to this game so they could buffer its graphics and cinemas and whatever so they can take some of our money. Of course, it's all about cutthroat business. They did a damn good job on it, for your information. I hope you will enjoy the game and this FAQ.

Thanks!

=====
B) -- Copyright --
=====

This FAQ/Walkthrough is (c) 2004 to Michael Tincher and Martin Dale-Hench. It may not be used for your own profit or on any other site without our permission. If you see this FAQ/Walkthrough on any site that is NOT on our Site Permission List, please contact us immediately. If you would like to use this FAQ/Walkthrough on another site, contact us and ask us if you can use it. If we allow you use it, please don't change anything about the guide and give us proper credit.

You may print this guide out for YOUR OWN PERSONAL USE. Do not print this guide out, then attempt to sell it. If you do not want to kill a tree by printing this guide out, you can save it to your hard drive for your personal use.

=====
C) -- Site Permission List --
=====

- GameFAQs <http://www.gamefaqs.com/>
- IGN <http://faqs.ign.com/>
- Neoseeker <https://www.neoseeker.com/>
- Cheat Happens <http://www.cheathappens.com/>

=====
D) -- What's New --
=====

1.0 - Some changes, mainly the format.

- June 15, 2004

0.8 - First version submitted. There are still a few appendices to do before the FAQ/Walkthrough is fully complete.

```

-----
(  _  _ )
 |  |
 |  |
 |  |
 |  |
-----
                                     (  _  _ )
                                     |  |
                                     |  |
                                     |  |
                                     |  |
-----
                                     II. Basics
                                     |  |
                                     |  |
                                     |  |
                                     |  |
-----

```

```

=====
A)                                     -= Controls -=
=====

```

Control Stick --- Move character (Solid Snake).

A Button ----- Attack button. Will use weapon/item if equipped, and chokes or throws enemy (if behind enemy).

B Button ----- Punch Button. Tap this repeatedly to do a punch, punch, kick combo. When leaning on a wall, use this to tap the wall to produce sounds.

X Button ----- Crouch or Stand Up from crouching.

Y Button ----- Action Button. (Climb up ladders, open doors, push buttons, etc.)

L Button ----- Activate Item Menu. Tapping this will allow you to de-equip/equip items quickly. Also can be used to peek around corners when leaning against a wall.

R Button ----- Activate Weapon Menu. Tapping this will allow you to de-equip/equip items quickly. Also can be used to peek around corners when leaning against a wall.

Z Button ----- First Person View.

C Stick ----- Move Camera in the corner camera mode.

```

=====
B)                                     -= Codec -=
=====

```

Name	Frequency	Purpose
Roy Campbell (Colonel)	140.85	Provides you with some general information.
Naomi Hunter	140.85	
Mei Ling	140.96	Saves your game.
Nastasha Romanenko	141.52	Gives you info about weapons

I apologize for an extra-long explanation of this devilishly simple introduction to the game, but I had to get the 'basics' out of the way. From now on, I will have to assume you know the basics and just say what you have to do, not how. Good luck!

MAP - CARGO DOCK

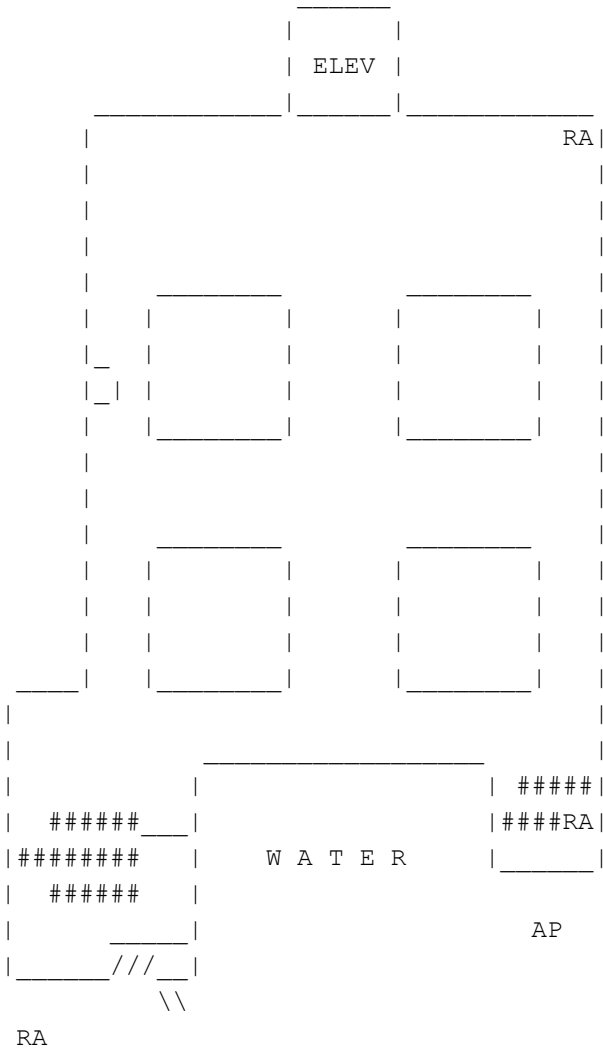

-
Heliport
*-**

A much easier field to go through here. After learning about Liquid Snake and his Hind D, you meet Mei Ling. Call her at 140.96 to save your mission at any time. She's quite helpful... and cute. :)

Now, there is an easy *RATION* to access in the snowfield to the right. If you act quickly, the lone soldier in that area won't be able to see or hear you. Then, bypass that soldier to the truck (look at M9/SO in the map) and climb onto it for your first pistol, the *SOCOM*! Walk under it to discover another potent weapon, *M9*! M9 is a tranquilizer and SOCOM shoots regular bullets that.... kills people and shows blood! WHOO!

Then, there's a Storeroom (STORE in map) that is guarded by a camera. To get rid of the camera, you may shoot the camera when it's not looking at you with a SOCOM (hold Z and A to aim) OR get the Chaff Grenades at the middle of the heliport (be careful of the lights - pick it up when they are moving apart!)

and use it to disrupt the camera without making any noise. Quite effective.

Now, you want to get out of this cold hellhole. There are two of them, one on the upper floor (UPPER VENT), and one on the base floor (LV). Both of them has a guard all over it, but the lower vent is easier than accessing the upper one.

Lower vent - Just use M9 and hold down Z to aim at the sleeping guard by the vent. Aim for his head and if you made a perfect shot, he will fall down and resume sleeping. :) However, there is a camera nearby. Just hug the left wall and crawl to the vent to bypass it.

Upper vent - A bit more difficult. Dodge the camera by the stairs and go up. You may shoot the wandering guard on the balcony if you wish, or just wait for him to go to the other way and go for the vent and crawl through!

MAP - HELIPORT

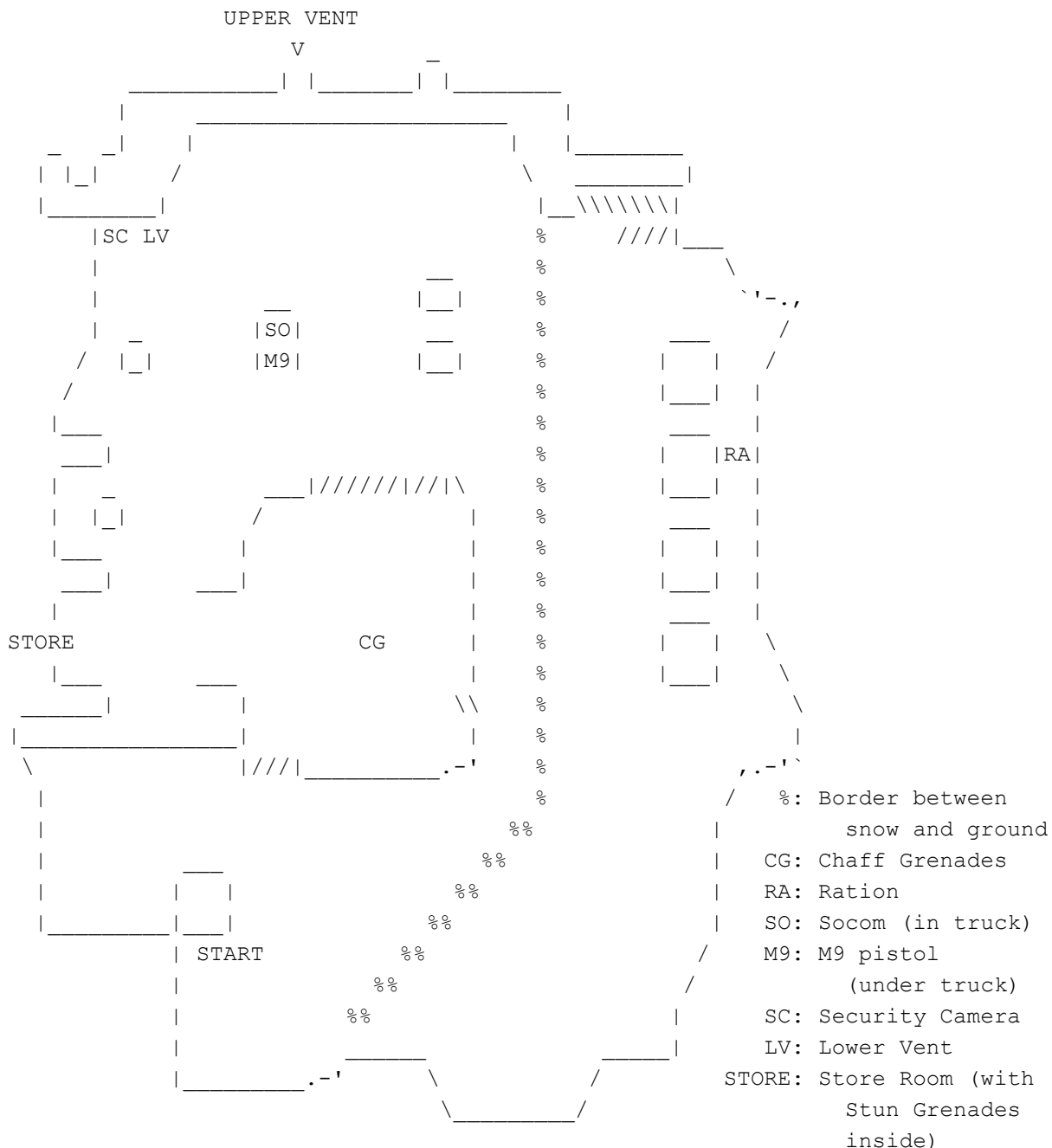

Canyon

*-**

WARNING! - There are several *CLAYMORES* right front of you and to the right. If you step over them, it will detonate and damage you greatly. You may crawl over them and collect them for your own use without any harm. Whoo! However, I recommend you to just go dead left to the corner and up (NO claymores in this path) to the *RATION*. Collect it and CRAWL north for a CLAYMORE and a scene. You will ignite a BOSS BATTLE!

BOSS #2 - 'TANK'

Your main weapon here is definitely the Grenades, but your main asset to surviving this battle is the Chaff Grenades, since it temporarily disables the cannon of the tank (as controlled by Vulcan Raven). Throw a Chaff Grenades before moving and wait for it to start working. Then move out of the rock you're behind and head for the tank. Equip your Grenades and go around the tank in circles (avoid its cannon and the gunner!). When you think you're not targeted by either of the guns, stop and turn your body toward the gunner in the middle and throw a Grenade toward him. If it's a bull-eye, a brief scene will show a Grenade landing onto the Gunner's lap. Soon after, the Grenade will explode and inflict damage to 2/5 of the Gunner's health. Big money, baby! However, if it was not a bull-eye but pretty close to the Gunner, it will do about 1/5 of the damage. After each hit, the Gunner will return to the tank to tend care of itself. Therefore, don't throw a barrage of Grenades after he is hit... wait for him to get back up and resume your throwing.

There are two Gunners in all, so don't think you've won when the health bar goes down! Since the battle can be drawn-out, there are items in the far north/northeastern border. Also, there are several items in the trench to the north.

Also, there is a way to stop the Tank from moving - place a Claymore or C4 or Grenade or whatever near a tank. If it explodes near a wheel, it will destroy the wheel. If enough of them are disabled, the tank will stop moving. It will make your battle MUCH easier.

Keep moving in circles and you shall be the victor!

After the grueling battle, the Tank is obliterated by Solid Snake and you finally access the 'Warehouse to the north'. Whoo!

*-**

Nuke Building 1F

*-**

Go on the path to the left to find a *RATION*. Go down to the right path and crawl through the tiny opening. Suddenly, Colonel Campbell and Naomi calls you and states that you CANNOT use ANY weapons here. Darn.

There are two soldiers patrolling the base floor, and one more paces on the catwalk above. The Elevator is on the catwalk, so you got to go up there. You may use the left or right staircases, but I prefer the left one. Either way works. There is *SOCOM AMMO* in the truck to the north, by the right staircase. *GRENADES* and *M9 AMMO* are in the lockers to the west. I

track him down with your SOCOM or M9. Then, head to the right to find your newest bad-ass weapon - the *NIKITA*! Pick the *NIKITA AMMO*, too. Open the lockers for a *RATION* and *M9 AMMO*. Don't forget the *STUN GRENADE* in the corner and return to the elevator to go down to B2.

*The doors here are above LVL. 3, so you will not be able to access any of the rooms here yet.

MAP - NUKE BUILDING B1

To Commander's Room

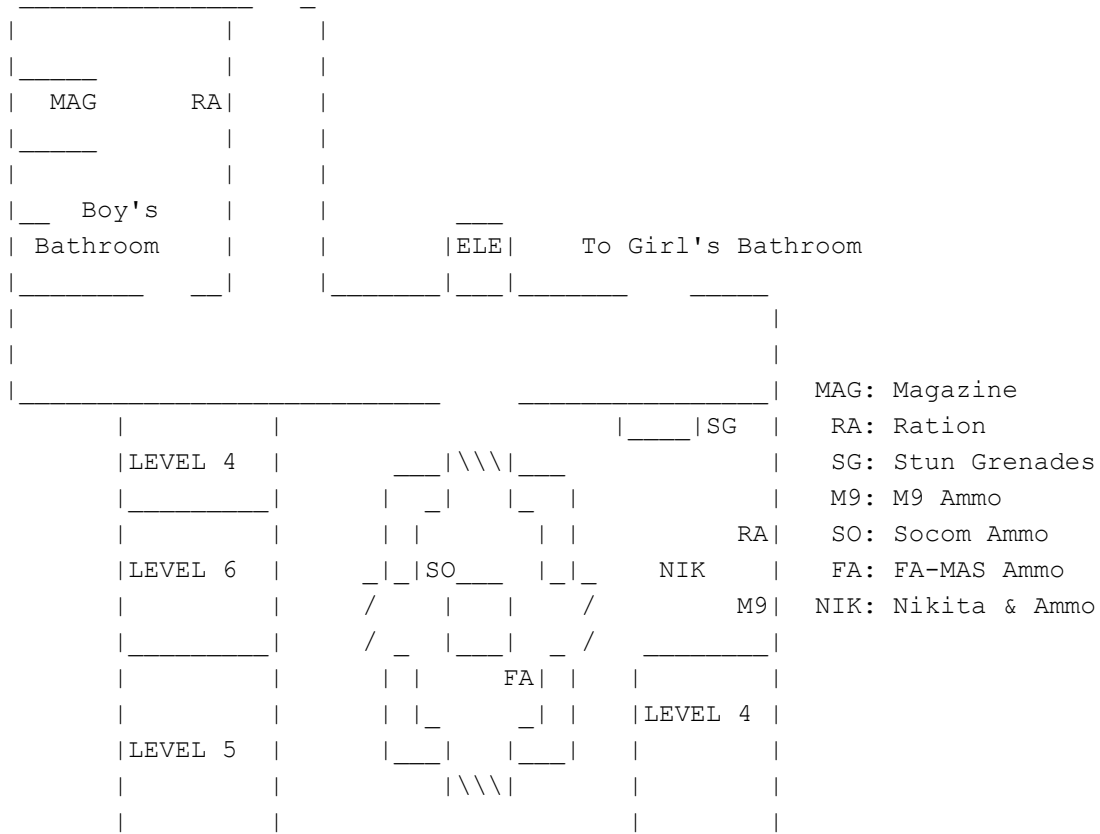

Nuke Building B2

Enter the next doors and suddenly, some gas comes out, partly suffocating you! A cutscenes helps you to understand that there is a electric panel out of your reach that generates the electric floor. Now, if you managed to disable the panel, you would have an easy access to the entire floor, right? RIGHT!

Take your Nikita out and fire one down the hall and turn right. Now, the left room has FOUR Gun Turrets that will attempt to destroy your sweet little missile. How do you avoid them? The trick is NOT to slow down. Just go right once you enter this room and let the Nikita FLY! Do not change direction, since it will slow the missile down. When the missile nears the northern end of the room, you may change the direction so it will enter the room to the north. Then, go to the right and hit the panel for once and all! WHOO!

Go back to the previous room to get your oxygen level up. Then, enter the

Backtracking to the Armory

Backtrack your steps to the entrance and enter Commander's Room. Then continue on to Nuke Building B1. Use the elevator to go up to 1F and sneak by the guards to the Canyon (remember, you have to crawl under the ajar door). In the Canyon, there are some guards and cameras now. You could either hug the wall and move when the guards look away or take down from a distance with your M9/SOCOM.

Back to Tank Hangar... No lasers are here now, so no worries. Take the elevator down to B2... finally!

Armory

First, I would like you to get rid of the guards (2) here. After that, just clear the rooms (you can access ALL of them now!). In the NW room, there is the PSG-1 that you needed, but take your Goggles out and you will see some lasers blocking it. Just crawl under it and you should be fine. Here's the map of the Armory again (below).

After collecting the sniper rifle, return to the Nuke Building!

MAP - ARMORY

TT: Trap
 BB: Bomb-able walls
 L2: Only opened with level 2 card

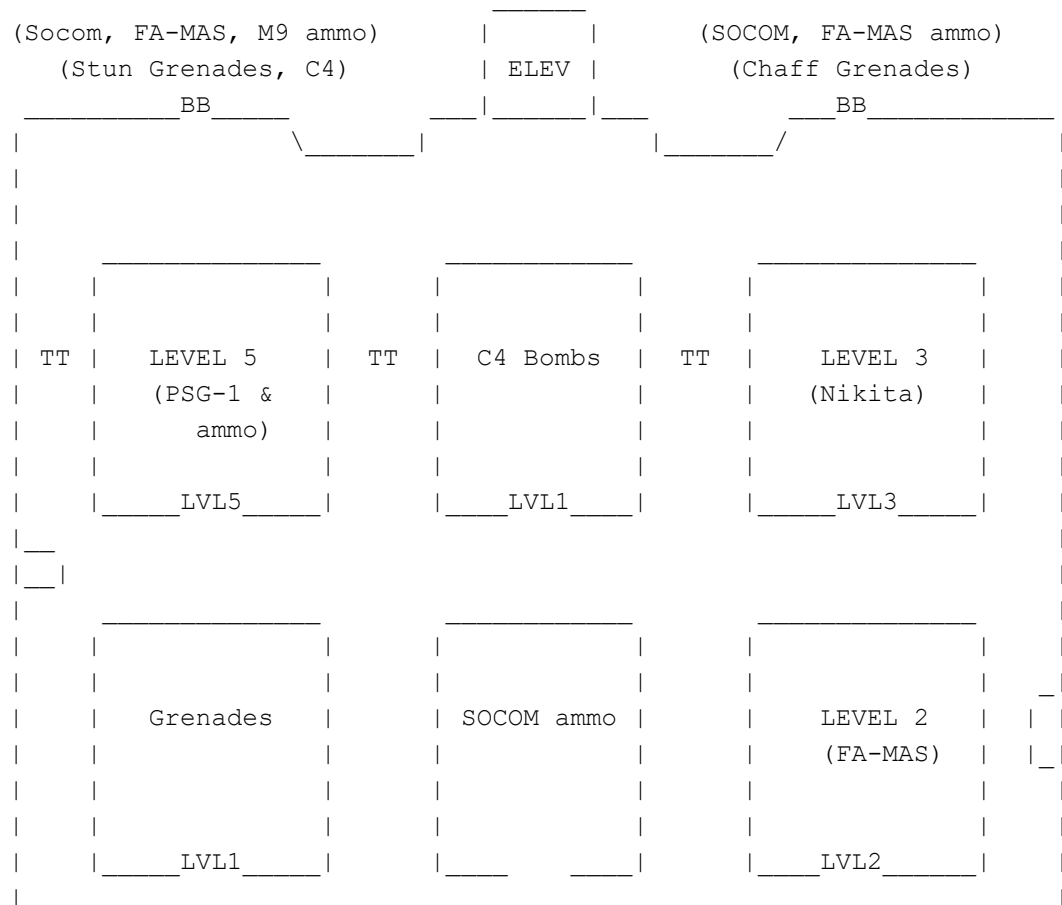

```

| _____ |
| _____ |
|_BB_____ |   | _L2_____ |   | _____ |

```

-----*

Backtracking to Underground Passage

Go back the same way you came here. Go up to 1F (Tank Hangar), then the Canyon, and finally 1F of the Nuke Building. Go down to B1 and stop there.

-----*

Nuke Building B1

Take the guard in the main room out. Now, you have the LVL. 5 card, so you are able to open three of the rooms here. Rake in the goodies from those rooms. The items that you can find here are shown on the map. The most important item is the *PENTAZEMIN*, it allows you to calm your nerves and jitters down and give you an accurate shot. After all of that, go north to the Commander's Room and resume your journey back to Underground Passage via the Caves.

-----*

MAP - NUKE BUILDING B1

To Commander's Room

```

|_____ |   |
|_____ |   |
|  MAG   RA |   |
|_____ |   |
|
|_  Boy's  |   |
| Bathroom |   | |ELE|   | To Girl's Bathroom
|_____ |   |
|
|
|_____ |   |
|_____ |   |

```

- MAG: Magazine
- RA: Ration
- SG: Stun Grenades
- M9: M9 Ammo
- SO: Socom Ammo
- FA: FA-MAS Ammo
- NIK: Nikita & Ammo
- CB: Cardboard Box
- PSGT: PSG-T Rifle
- PTA: PSG-T Ammo
- PEN: Pentazemin

-----*

Underground Passage

that the elevator was working. After quite a bit of boring, pointless rambling, Otacon finally decides to leave. If you came to this area before you went down the stairs beside the Level 6 security door, you should have noticed that there were boxes blocking the stairwell beside the elevator. Now, it seems as though someone has displaced these boxes, opening up an entrance to the stairwell. Hurdle up the stairs. On your way up, there will be four landings that have camera guns. There is a pattern that allows you to know what landing will have gun cameras. The pattern is that every fourth floor has the specialized cameras. The first gun landing contains only one gun, the second two, the third three, and the fourth four.

At the very top landing will be a ladder for Snake to climb up. But before you climb the ladder, you may want to run around the catwalk here and collect the FAMAS bullets, Stinger missiles, Chaff grenades, and the Ration.

Communications Tower Roof

- ~~~~~
- | | | |
|--|------------------------------------|--|
| | KEY | |
| | ----- | |
| | 1 - Exit of Communications Tower B | |
| | R - Ration | |
| | ST - Stinger Missiles | |
| | B - Bandage | |
| | = - Staircase | |
- ~~~~~

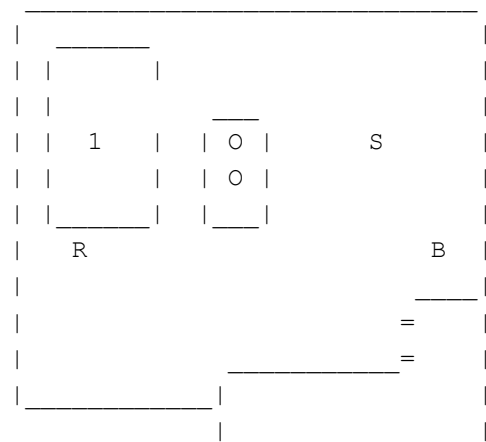

Upon reaching the roof top, a cut-scene occurs with Liquid Snake in his Hind D helicopter. Immediately afterwards, he will begin to attack, starting a boss fight against the Hind D.

Boss Fight #6 - Hind D

If you stay between the exit from the Communications Tower to the roof top and the large fuel tanks, then this will cut down on the damage received by Snake from Liquid's gunfire. However, there is a downside to this, which is the helicopter becomes more difficult to hit. Beside the Communications Tower B entrance/exit is a Ration. Between the tanks and the edge of the tower, in the large clearing, is a set of missiles for your Stinger. You must equip your Stinger missile launcher. This is the only weapon that will penetrate the Hind D. When it is equipped, you will be placed in first person view of the

strangeness of the elevator before each realize that there are four other guys inside the elevator, each one wearing a Stealth Camo suit. Quickly grab your FAMAS and blast away at the four guards. You can also throw the guards into each other, knocking at least two down at a time. Or use Snake's combo, flaying the guards into each other on the kick part. Each guard, once defeated, will leave behind a box of FAMAS bullets.

```

~~~~~
|                               |
|             KEY               |
|-----|
| GC - Gun Camera              |
| R - Ration                   |
| M9 - M9 bullets              |
| PT - PSG1-T bullets          |
| P1 - PSG1 bullets            |
| SO - SOCOM bullets           |
| CG - Chaff Grenades          |
| FA - FAMAS bullets           |
| PE - Pentazemin              |
| LVL 6 - Level 6 Security Door|
|                               |
~~~~~

LVL
_6
| GC|#| M9 |          BLOCKED          | |
| PE|#|    |          OFF              |
|  |#| PT|_____|
|  |#|    |
|  |#|    |
|  |#|    |
|  |#|    |          FA              |
|  |#|    |          Elevator         |CG|
|  |#|    |
|GC |#|    |
|  |#| R |
|  |#|    |          EXIT              |
|  |#|
|  |#|_____LVL 6_|
|   |#####| P1 |
|   |#####|
|FA  _____SO|   GC|
|   FA          LVL 6   P1 |
|GC_____|

```

Upon reaching your destination, step out of the elevator. If you look at the map above, you will see where all of the items are located at in the room that you enter after exiting the elevator. Once you have stepped off the elevator, take a left with Snake (your right), and go through the Level 6 door in the corner. This room has two sets of PSG1 bullets, as well as a Gun Camera. Across from the Gun Camera is another Level 6 clearance door for you do go through.

On the right is a set of SOCOM bullets. Carefully walk down the hall. Get in first person view and watch where the gun camera goes to. When it is facing around the corner, away from you, sprint up to the boxes and kneel down. Wait until it is facing the way you just came from before you take off on down the hall. About midways through this hallway is a gun camera. Continue under it, and to the end of the hall. At the end of the hall is a packet of Pentazemin,

Sniper Wolf will run back and forth, and hide behind the trees that are on the otherside of the Snowfield area. The easiest way I found to discover where she is without getting hit is to stand on the right side of the tree that is on the left end of the snowfield. If Snake is under the tree, it makes it difficult for her to spot him.

While under the tree, wait until you see a red laser beam being pointed at Snake. When this happens, face in the direction of the laser, and equip your sniper rifle, either the PSG1 or the PSG1-T. After the sniper rifle is equipped, you should have Sniper Wolf in your cross hairs. Shoot her, and follow where she went by using the scope of your sniper rifle. If she goes behind a tree, then aim at the middle of the tree and wait until she steps out. At the moment she steps out from behind it, place your cross hairs on her, and pull the trigger. If you are not quick enough, she will shoot Snake before he has a chance to get trigger happy. Also, don't forget to use the Pentazemin pills to steady Snake's shaking.

The best time to shoot Sniper Wolf is when she is running from tree to tree. This leaves an open shot to her body for you. If you are wanting to shoot her in the head, then wait until she tries to aim her rifle at Snake. While having the sniper rifle equipped, if you see a red beam flash in front of Snake, you should know that Sniper Wolf is aiming at Snake, attempting to get the perfect kill shot. If and when she does do this, you have two options. To unequip Snake's rifle and run to cover, or quickly find her in the scope and blast her with a bullet. If Snake is ever shot while having the rifle eqipped, you will have to unequip the sniper rifle, then re-equip it.

Once it seems as if you have defeated Sniper Wolf for the last time, she comes back with one last fight in an FMV. Before she is able to shoot and kill Snake, he shoots her in the lungs. This places an end to the attacking of Sniper Wolf, but not her life...yet!

As soon as you regain control of Snake, run to the center of the field. A sad scene will occur. Sniper Wolf, knowing her life is coming to an abrupt end, tells Snake her life story. Otacon approaches, and tells Sniper Wolf that he loves her. Then, she asks Snake to end her suffering. Obeyingly, Snake does so with his SOCOM.

All of the surrounding buildings contain ammunition and items. Scavage around in these building if you want anything, but be careful of the mines and gun cameras that are enclosed in some of the buildings.

~~~~~  
Building W-A2  
~~~~~

Within this building are four boxes of Nikita missiles, Cardboard Box 3, and one gun camera.

~~~~~  
Building W-A1  
~~~~~

This building has a ration and a bandage within it's confines. There are also two gun cameras awaiting Snake's arrival.

~~~~~  
Building E-A1  
~~~~~

Located inside Building E-A1 are two boxes of grenades and two boxes of Chaff

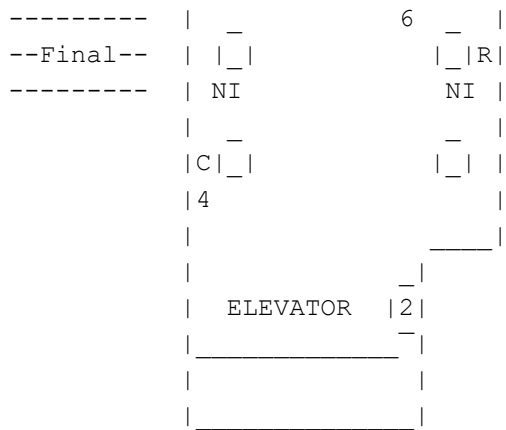

Run behind all of the boxes in this area to collect the available ammunition. When ready, walk onto the elevator, step up to the control panel, and press the Action, Y, button. Make sure that Snake has the FAMAS equipped before he begins to go down. While peacefully descending, Snake will be attacked by four guards. Quickly eliminate them with your FAMAS. For a challenge, use the combo that Snake knows, or throw the guards around.

Once they are defeated, the elevator will go down a little bit more before coming to a stop. When the elevator stops, walk off, and go around the corner. Watch out for the gun camera though. Destroy it by shooting the camera. Run to the corners of this large room to pick up Claymore mines, a ration, and a set of FAMAS bullets. Then, stroll onto the elevator, stride to the control panel, and press the action button.

This time while slowly going down, a flock of ravens will surround the elevator. DO NOT touch these ravens. If you hit one of the ravens, the whole flock will attack Snake. About half way down, Snake will receive a call from Master Miller. Miller tells Snake that Naomi lied about her background, and about her grandfather being in the FBI. Master Miller gives evidence to persuade Snake that Naomi was lying. Was she really lying to you and Snake? Time will tell.

When the elevator finally stops, run off. Check behind, and in between the boxes to discover two sets of Nikita missiles, a set of C4, and a ration. Then, proceed through the Level 6 security clearance door on this floor.

The Cold Warehouse

- ```

~~~~~
|                KEY                |
|-----|
| R - Ration |
| SO - SOCOM bullets |
| FA - FAMAS bullets |
| M9 - M9 bullets |
| NI - Nikita Missiles |
| CM - Claymore Mines |
| LVL 7 - Level 7 Security Door |
| /// - Boxes may fall in these areas |
~~~~~

```







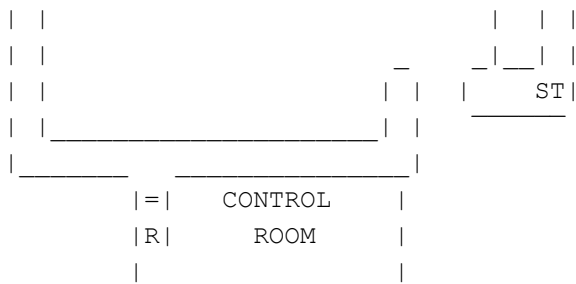

Head straight down the corridor, into the opening with Metal Gear Rex. As soon as Snake reaches this point, take a right along the pathway. When you reach a set of stairs leading to the second level, Otacon calls in on the CODEC. Otacon tells Snake that Metal Gear Rex is almost ready to launch, and the only they can do to stop the luanch is to use the three keys that Baker talked about earlier. There is one problem with this solution though, Snake only has one of the three keys. Otacon plans to hack into Baker's files to discover the trick about the three keys.

Walk up the stairwell that takes you to the second level. From here, take a left at the top, then go upwards at the next interval. Quickly, Snake will reach another stairwell. This one leads to the third floor. On the third floor are two Genome soldiers patrolling the area. At the top of the steps, Snake and Otacon have a brief talk over the CODEC. I suggest that you take a right at the top of the stairs, and take the guard out on that end. Then back track to the stairs, go past them on the left, and eliminate the guard on this side.

After the second guard has been taken care off, continue in the direction you were going. Sometime, you should receive yet another call from Otacon with him informing Snake that he has just hacked into Baker's files. They also talk more about newly discovered information about Metal Gear Rex.

Keep walking along the catwalk. Once near the end, Otacon rings in again. This time he tells Snake about how everything seemed to be riding on the Metal Gear Rex project. After cutting around a corner you should see a set of steps. Walk up the steps to start a lengthy FMV.

The FMV displays Ocelot and Liquid talking to each other. The nuke is now ready to launch, but there was a change of plans on where the weapon will hit. Instead of in Russia like planned, Liquid decided to shoot at a nuclear test site in China. After a TON of rambling, Otacon buzzes in and tells Snake that he already has the three override keys. The PAL Card morphs when exposed to different temperatures, revealing three different keys. After the convo, Ocelot spots Snake and the PAL Card. Revolver Ocelot, within no time, pulls out his pistol and shoots the card out of Snake's hand.

Snake must now find the PAL Card, which just feel in the drainage ditch. Go down to the first floor, and enter the drainage ditch at one of the two entry locations. The first is beside where you entered the large area with Metal Gear Rex. To get to the second, get to where Snake entered the large area with Metal Gear Rex, and take a left, instead of a right like earlier.

Anyway, hop in the drainage ditch and rummage around. Be careful because the greenish water in here is toxic and slowly depletes Snake's health. If you do not quickly find the card, Master Miller calls in on the CODEC and says that a large rat may have eaten the card. If this is so, then go to the second entrance to the drainage ditch. At the top is a hole that a rat may have crawled into. Place a Claymore mine in front of the hole, and wait. When the rat comes out of the hole, the mine will blow up, revealing the PAL Card.

Now, go back to the room that Ocelot and Liquid were just in. DO NOT go in just yet. Throw a Chaff grenade in the room before entering. If you do not, Snake will set off a camera that locks up the room, then fills it with poisonous gas. Once you have thrown in the Chaff grenade, walk, and equip your SOCOM. There is a camera beside the door, in the corner. Shoot it, then go over to the otherside of the room. Over here is another camera. Destroy it with your SOCOM just like the other. Stroll over to the three computers, and put the PAL Card in the computer furthest left by pressing the Action (Y) button.

As soon as that is through, you will need to get the card cold, followed by heating it up. There are two different methods of doing this. The first is back tracking back to the room that you fought Vulcan Raven to make your card cold, and going back to the Blast Furnace to get it hot. The other way is staying on the third floor where the control room is. Walk out of the control room, and walk ALL THE WAY around the catwalk. Right before you cut the corner that leads to a dead end, get up against the railing, and drop down. Catch onto the railing below, which is on a platform all to itself. Here are two pipes. One pipe is labeled Liquid Nitrogen (the one on the right), while the second is entitled Steam (the pipe on the left).

Get out your SOCOM, equip your PAL Card, and shoot the Liquid Nitrogen pipe. Stand in front of the air coming out just long enough to freeze the card. Then, grab onto the railing, drop down and catch the cable, followed by hopping down onto the first floor. Do the same thing to get the card hot.

Which ever way you choose to get your card cold and hot, make sure that you freeze the card, go to the control room, input the card into the middle computer, then heat the card and place it in the computer on the right.

After heating up your PAL card, while sprinting to the control room, Snake receives a surprise call from Naomi on the CODEC. Wait...wasn't she arrested? That is correct, she was arrested. Now it is her turn to tell her side of the story. She also tells Solid Snake about FoxDie. Before Naomi has a chance to finish her conversation, she is caught by Colonel. As soon as Campbell has finished talking to you, go on into the control room and insert the PAL card into the third computer.

Once the third PAL code has been put in, an FMV starts. Instead of deactivating the launch by using the PAL cards, Snake has activated it. Snake gets a call from Master Miller, thanking him that he activated Metal Gear Rex. Master Miller's voice should start to become familiar. Have you recognized the voice yet? Well, if you haven't, it will soon be revealed.

Campbell interupts and tells Snake that that is not Master Miller, and that Miller's body was just discovered, having been dead for days. Finally, the impersonator reveals himself. It is Snake's very own brother, Liquid Snake.

The control room becomes locked, and begins to fill up with poisonous gas. If you use your CODEC to contact Otacon, he says that he will unlock the door. Run up to the door, and Otacon will unlock it for you. Walk out of the room, and watch the lengthy cutscene that shows the Twin Snakes confrontation.

"Les enfants terribles."

-----  
Boss Fight #9 - Metal Gear Rex  
-----







two different checkpoints where you are required to blow up the blocked passageways. Do not worry about the guards in these areas, just aim for the tanks of fuel.

Liquid Snake will emerge in a jeep after the destruction of the two checkpoints. Didn't Liquid die when he was knocked off of Metal Gear. Well, it looks like he is a survivor. To quote Kellen Winslow II, "I'm a soldier!" Continuously shoot at Liquid with the machine gun, and the unlimited supply of ammo. After a little while of shooting, Liquid will start to ram his jeep into the back of your jeep. This will decrease the health of Solid Snake.

Once you have successfully hit Liquid a few more times, he will try to pass Snake and his partner. Continue to shoot at him until an FMV starts. Watch the FMV and see how the story unfolds, and the game comes to a conclusion.

```

() ()
| |
| |
| |
IV. Spoiler-Free Guide

| |
| |
| |
```

```
=====
A) -= Disc One -=
=====
```

```

-= Cargo Dock -=

```

- Crawl under the tanks, and head towards the elevator. Hide behind the forklift until it comes down, then get on, and ride up.

```

-= Heliport -=

```

- Go through one of the two duct vents to infiltrate the base.
- Squirm through the vent.

```

-= Tank Hangar -=

```

- Lower yourself from the catwalk to the floor below. Then, access the elevator and go down to B1.

```

-= Holding Cells -=

```

- Venture to the end of the hallway, and ascend the presented ladder into the air duct. Go through the vent until you achieve your first completed

objective.

- Shoot all of the guards that charge towards you.
- Get on the elevator, and select to go down to B2.

-----  
-= Armory =-  
-----

- Walk into the top-middle room to get a few C4 explosives.
- Go to the bottom-right, and search around for an odd looking part in the wall. Once found, place a piece of C4 on it, and blow the wall apart.

-----  
-= Armory South =-  
-----

- In the new room that Snake walks in, there is another wall that was recently fixed that can be blown up.
- Go into the newly created entrance way, and you will see two patches that are able to be blown up.
- Place a C4 on the wall located to Snake's left, and enter.
- First Boss fight.
- Look on the back of the Metal Gear Solid: The Twin Snakes case, then get and use the CODEC number on the back.
- After contacting the person, go back to the Tank Hangar.

-----  
-= Tank Hangar =-  
-----

- Journey over to the large opening that is now beside the elevator. You will need thermal goggles to get past this next part. If you haven't picked them up, then you will need to use the Cigs that are in Snake's inventory, but it will slowly retract his health.
- Crawl through the large opening, dodging all of the lasers in this area.
- Enter the door on the other side.

-----  
-= Canyon =-  
-----

- There are many Claymore mines placed throughout this area. To dodge them, go left, then up towards the ration.
- There is a Claymore above the ration, so crawl and pick it up.

- Snake will be engulfed in his second boss fight.
- Now that Snake has access to the building across the Canyon, go inside it.

-----  
-= Nuke Building 1F =-  
-----

- Sprint straight ahead.
- Crawl under the small opening caused by the large retractable door not being sealed.
- Sneak up one of the sets of stairs, then enter the elevator and go down to B1.

-----  
-= Nuke Building B1 =-  
-----

- Take a left here, and enter the men's restroom.
- Eliminate the guard in this area.
- Exit the restrooms, then proceed through the door that was opposite the elevator.
- Kill the guard in here, then get the Nikita missile launcher that is on the right side of the room, in the open space.
- Leave this room, hop on the elevator, and go down to B2.

-----  
-= Nuke Building B2 =-  
-----

- Enter the doors straight ahead.
- Continue to enter the doors until Snake enters a room filled with gas. A cut scene occurs, and shows you that you must shoot out the breaker to continue.
- Take out your newly found Nikita, and control it to the breaker box.
- Move across the now harmless floor, and go down the hallway opposite of where you controlled the missile.
- Exit this small room, then go through the door that you see when Snake exits the air locked room.
- Walk down the hall, go around the corner, and enter the door.
- Snake will now go into his third boss fight.
- After Snake's victory, go back to Nuke Building B1.

-----

-- Nuke Building B1 --  
-----

- Enter the room below the elevator.
- Walk up to the guard in this room. The Genome soldier will run out of the room, and into the women's restroom. Follow the person into the women's.
- Once the scenes are over with, exit, go towards the men's restroom, and traverse through the hallway beside it, and into the Commander's Room.

-----  
-- Commander's Room --  
-----

- You will be engaged in the fourth boss fight in the game after you control Snake through another set of doors, and you watch a couple of scenes.
- Pass through the door that was revealed behind a bookcase. Scurry down the steps, and through the door in this small room.

-----  
-- Caves --  
-----

- Stride through the caves, and crawl at the needed points.
- Eventually, you will get to a security door that leads to the Underground Passage.

-----  
-- Underground Passage --  
-----

- Follow the same path across the small area of mines that Snake's partner did.
- Watch the heartbreaking scenes that follow.
- As soon as the FMVs are completed, Snake will need to get a sniper rifle. You can back track all the way back to the armory to get the more powerful of the two sniper rifles available. When you reach the Armory, sprint to the elevator, and journey down to B2. In here, enter the room that is on the top-left. Watch out for the lasers that are in here. This will get you the PSG1. To get the other sniper rifle, also the weakest, go to Nuke Building B1. From here, go in the large room below the elevator. In here, enter the room that is at the bottom left to retrieve the PSG1-T rifle, along with some Pentazemin to keep Snake from shaking.
- Now, go back to the Underground Passage and enter the fifth boss fight of the game.

-----  
-- The Torture Room --  
-----

- As soon as all of the scenes have completed after the defeat of the fifth



- After the scenes, go up the stairs until you reach the 29th Floor.

- Climb up the ladder on the 29th Floor.

-----  
-= Communications Tower Roof =-  
-----

- Go out of the small room that the ladder led to.

- Snake will now be entered into this sixth boss fight of the game, and the first of the second disc.

- After the battle, enter back into Communications Tower B.

-----  
-= Communications Tower B =-  
-----

- Descend down the long flight of stairs.

- Enter the elevator when Snake reaches it.

- Annihilate the guards that try to attack Snake on the elevator.

- Exit the elevator, and down to the right, and through the door.

- Hurry down this small hallway, and out the door to the Snowfield.

-----  
-= The Snowfield =-  
-----

- As soon as Snake enters this area, he will be engaged in his seventh boss fight.

- After the battle, run across the field, and into the room that is in the top-left.

- Speed through this small hallway, down the stairs, and into the Blast Furnace.

-----  
-= Blast Furnace =-  
-----

- Eliminate the guard patrolling the top floor. Then, go down the catwalk that is closest to the door Snake just went through.

- Slowly walk across the small ledge. Watch out for the crane that is sliding back and forth.

- Glide down the steps. Take out the guard on this lower floor, then proceed through the large doors to go to the Cargo Elevator.

=====  
== Cargo Elevator ==  
=====

- Walk onto the elevator, and press the Action button at the control panel.
- Kill the four guards that attack you.
- Rush off of the elevator, then hop on the other elevator on this floor.
- Hurry through the level 6 security door, and into the Cold Warehouse.

=====  
== Cold Warehouse ==  
=====

- Defeat the eighth boss of the game.
- Run into the Level 7 Security Door.

=====  
== Warehouse North ==  
=====

- Walk through the hallway. Watch out for the two trapdoors, and the two guards that are patrolling the area.
- Enter the Level 7 door in this area. There are two gun cameras above the door.

=====  
== Underground Base ==  
=====

- Go up the stairs until you are on the third floor.
- Eliminate the two guards patrolling this floor.
- Head towards the Control Room.
- After the FMV, go down to the first floor and search for the PAL Card in the discolored water. If you are unable to find it quickly, find the rat hole that is on the upper left end of the first floor, and place a Claymore mine in front of it. A rat will soon run out, and will blow up, giving Snake back the PAL Card.
- Go back to the Control Room. Throw a Chaff Grenade inside before you enter, then shoot out the two cameras in here.
- Walk over to the set of three computers. Insert the PAL Card into the computer on the left.
- There are two different ways to get the PAL card cold and hot. You can traverse back to the Cold Warehouse, and the Blast Furnace. Or, you can take Snake to the otherside of the third floor catwalk. When you reach the corner before a deadend, hang on the railing, then jump on the platform



below. Here there are two pipes that Snake can use.

- Freeze the card, then insert it in the middle computer.
- Heat up the card, then insert it in the computer furtherest right.
- After all of the cutscenes, call Otacon to have him unlock you from where you are at.
- Walk out of the room, and watch the many cutscenes.
- Snake will now fight the ninth boss of the game.
- You must fight the tenth and final boss after beating the ninth boss.

-----  
 -= Escape Route =-  
 -----

- Sprint through the small hallway, and past the door on the otherside.
- Shoot the guards while your partner gets a running jeep.
- Hop in the jeep, shoot the barrels, and take off.
- Shoot the barrels at each checkpoint.
- Fire at the enemy that attacks you after the second checkpoint.
- That is it. You have beaten the game!

|   |               |   |
|---|---------------|---|
| ( | =====         | ) |
|   | V. Plot Guide |   |
|   | =====         |   |
|   | =====         |   |
|   | =====         |   |
|   | =====         |   |

**\*SPOILER ALERT!\* DO NOT READ UNTIL YOU HAVE BEATEN THE GAME!**

This is written by Martin Dale-Hench, so if you have any questions/complaints/ comments, please direct those to him.

---

First you have to understand how Solid Snake and his brother, Liquid Snake, came to life. One of the greatest warriors in the realm of Metal Gear universe, Big Boss, had fallen to his doom. In an effort to keep his great mind, body, and instincts intact to their advantage, United States government ordered their scientists to produce off-springs of Big Boss, using his genes. Those scientists, indeed, did succeed. There were 7 offsprings, and they were known as "Les Enfants Terribles", or the Terrible Children. Four of those offsprings were disregarded because they did not contain Big Boss's most critical genes. Only three remained: Solid Snake, Liquid Snake, and Solidus Snake.

In the game, Liquid Snake said that he got his angst against Solid Snake and the rest of the world from knowing that he is the 'inferior' one. You later find out, in the ending, that he is actually the superior one, with Solid the inferior. The reason for that is because Hideo Kojima, the game's main

producer, wants to show that a person is not chained to fate, and he can dictate his future. As for the genes of Solidus, you will have to play Metal Gear Solid 2 to learn more.

Liquid, after falsely learning that he is, supposedly, the inferior one, assembled a group of outcasts, known as the "FOX-HOUND". The members are: Decoy Octopus, a master of manipulating the body; Revolver Ocelot, a expert marksman; Psycho Mantis, a mind-reader; Sniper Wolf, another marksWOMAN; Vulcan Raven, Injun warrior; and of course Liquid Snake, the mastermind. Those people are rejected by the society and are seeking for revenge against those people that has detested their whims and idiosyncaries. The terrorist organization has seized a brand new high-tech weapon of war, called Metal Gear REX (Rex = king in latin) from the United States of America. Now, they are asking for ransom money of \$1 billion, the genes of Big Boss so they can enhance their army of Genome Soldiers, and a vaccine for FoxDie.

What is FoxDie? It is a virus injected by the United States of America into certain, unknowingly, warriors to test its effectiveness. Liquid Snake and his comrades in FOX-HOUND all have it, Solid Snake got it from Naomi Hunter, and President Baker also has it. All of them needs a vaccine, but only Liquid Snake and FOX-HOUND know about it. We see the effectiveness when we see Decoy Octopus, as the DARPA chief, President Baker, and of course, Liquid Snake dies from it.

More to come soon...

```

(_ _) (_ _)

```

```
=====
A) == Item List ==
=====
```

.....

AP SENSOR

.....

Where found: Cargo Dock - Underwater, to the southeast.

Purpose : Alarms you of approaching lifeforms by rumbling the controller.

Directions : Just equip it. Wavebird controllers will be not 'rumbled'.

Other : Should be useful when you're playing without a radar. Or when you are on the ALERT mode.

.....

BANDAGE

.....

Where found: Communication Tower Roof B; In one of the rooms in the snowfield (2nd battle with Sniper Wolf); and some others

Purpose : Stops the bleeding.

Directions : Highlight it and press A.

Other : When your HP is in RED, you are bleeding. Use a Bandage to stop bleeding. Why? Because bleeding will lower your HP!

.....

BANDANA

.....

Where found: Complete the game with Meryl's ending and start a new file from the file you saved on the previous game completion.

Purpose : Unlimited ammo when equipped.

Directions : Just equip it.

Other : You still got to reload, though.

.....

#### BODY ARMOR

.....

Where found: Nuke Building B2 and Blast Furnace

Purpose : Halves the damage when equipped.

Directions : Just equip it.

Other : Useful in boss battles.

.....

#### BOX 1

.....

Where found: Armory (B2) - SE room. Also found in Warehouse North if you missed it in the Armory.

Purpose : Hide from the guards, or to transport to Heliport.

Directions : Just equip it and you will be covered with the box.

Other : If a soldier sees you unmoved, he might get you onto a truck and transport you back to Heliport.

.....

#### BOX 2

.....

Where found: Nuke Building B1 - NW room (LV 4 door).

Purpose : Hide from the guards, or to transport to Nuke Building.

Directions : Just equip it and you will be covered with the box.

Other : If a soldier sees you unmoved, he might get you onto a truck and transport you back to Nuke Building.

.....

#### BOX 3

.....

Where found: Snowfield, in one of the northern rooms.

Purpose : Hide from the guards, or to transport to Snowfield.

Directions : Just equip it and you will be covered with the box.

Other : If a soldier sees you unmoved, he might get you onto a truck and transport you back to Snowfield.

.....

#### CAMERA

.....

Where found: In the secret room of Armory - B2. Bomb the wall to the right of the one where you entered the room with Ocelot. Use a LVL. 6 keycard to open the door to this room with the Camera.

Purpose : To take pictures, I guess. Ghost pictures are possible with this.

Directions : Equip it, use X to zoom in, Y to zoom out, and A to take a picture.

Other : Can be used when you complete the game with the camera in your inventory.

.....

#### CARD KEY

.....

Where found: Various points in the story, can't miss them.

Purpose : Opens locked doors.

Directions : Does't even have to be equipped! Just go up to the door and the

key will do it job!

Other : The doors will only open if the card number is high enough, however. LVL 1 card key wont open LVL 2 doors...

.....

CIGS

.....

Where found: You have it from the start.

Purpose : To reduce bleeding and detect invisible lasers.

Directions : Just equip it.

Other : BUT... it reduces your HP! Like the real thing! ^\_^

.....

DOG TAGS

.....

Where found: Soldiers everywhere

Purpose : Just to gawk at it, I guess. Can be seen in the DOG TAG VIEWER in the main menu, too.

Directions : Can't really use them.

Other : To get them, just sneak up behind a guard and hold him up by holding your gun up. Then, hold down B to walk to his front. Go to the FPV and point the gun at his face. He will shake his head and drop his Dog Tag off. As for the bosses, just shake their body around.

.....

GAS MASK

.....

Where found: In one of the rooms at B2 of Nuke Building.

Purpose : To allow more breathing in gas-infected rooms.

Directions : Just equip it.

Other : It won't make you invincible.. It will just slow your Oxygen bar down.

.....

HANDKERCHIEF

.....

Where found: Otacon gives it to you when you're in the jail cell.

Purpose : To prevent the wolves in the Cave from attacking you.

Directions : Just equip it.

Other : The wolves in the cave will think you're SNiper Wolf or one of her friends if you equip it. They won't attack you at all.

.....

KETCHUP

.....

Where found: Otacon gives it you when you're in the jail cell.

Purpose : Can be used to get you out of the cell.

Directions : When laying down, highlight it and press A. It will break, leaving a red stain underneath you.

Other : You have to use it before the guard sees you. If he sees the break, he will know it's a fake.

.....

MEDICINE

.....

Where found: In the Caves, and in the NW room of the Nuke Building B1.

Purpose : To cure your common cold, attained after you escape from the cell.

Directions : Highlight it and press A.

Other : None?

.....

#### MINE DETECTOR

.....

Where found: Tank Hangar - NE room of the balcony

Purpose : Detects mines, duh.

Directions : Just equip it.

Other : The mines will be seen on the radar along with their direction.

.....

#### MO DISK

.....

Where found: Gotten from Baker after the Ocelot fight.

Purpose : None.

Directions : None.

Other : Just a 'story' item. No use at all.

.....

#### NIGHT VISION GOGGLES (NVG)

.....

Where found: Nuke Building B2 - NW room

Purpose : See in the dark! Whoo!

Directions : Just equip it.

Other : None... makes you see stuff a bit easier, I guess.

.....

#### PAL KEY

.....

Where found: You get it from Baker.

Purpose : Activate/deactivate Metal Gear Rex.

Directions : Equip it in the front of the laptop.

Other : You have to freeze and heat it up to 'transform' it

.....

#### PENTAZEMIN

.....

Where found: Nuke Building, B1 Western Room and the room where you fight  
Sniper Wolf for the first time

Purpose : Calms your nerves down

Directions : Highlight it and press A

Other : Extremely useful when shooting a PSG-1 or PSG-T

.....

#### RATION

.....

Where found: Everywhere.

Purpose : Re-fills health.

Directions : Highlight it and press A.

Other : If you leave the Ration icon on the Item socket, it will re-fill  
your health automatically once your health runs out so you don'y  
have to worry about using it manually.

.....

#### ROPE

.....

Where found: Communications Tower A.

Purpose : To climb down the Communications Tower.

Directions : Just equip it and go to the side of the Communication Tower.

Other : None.

.....

SCOPE

.....

Where found: You have it from the start.

Purpose : See from a distance.

Directions : Just equip it. Press X to zoom out, B to zoom in.

Other : You can use it to look for guards, cameras, etc. from a distance.

.....

SOCOM SUPPRESSOR

.....

Where found: Tank Hangar, NE room on the base level. If you missed it, it will re-appear in the Underground Base (where you meet MG Rex) in the water.

Purpose : Silences your SOCOM.

Directions : Equip your SOCOM and have the Suppressor equipped at the same time.

Other : Now you can't get caught firing.

.....

STEALTH

.....

Where found: Attained in the end-game save file if you get the Otacon's ending

Purpose : Soldiers will not be able to see you. Bosses will still see you, however.

Directions : Just equip it.

Other : If you touch a soldier, it will go off. Lasers and cameras will still see you.

.....

THERMAL GOGGLES

.....

Where found: Tank Hangar - West side of the balcony

Purpose : Detects heat.

Directions : Just equip it.

Other : You will be able to see enemies more clear (see Ninja when he's invisible!), claymore mines, lasers, and you can see in the dark! Sweet.

.....

TIME BOMB

.....

Where found: After you pick your stuff up again, after the capture. Also found in the water in the Underground Passage.

Purpose : A time bomb... if the time goes off, it kills Snake.

Directions : highlight it and press A to throw it.

Other : Be careful! An instant death if you doesn't throw it off soon enough.

=====

B)

== Weapons ==

=====

.....

BOOK

.....

Where found: Men's Bathrrom (Nuke Building B1); Armory; and several others

Purpose : To catch soldiers' attention

Directions : Highlight it, and press A to drop it.

Other : A soldier, once he sees it, will sit down and read it. He's all yours now. :)

.....

C4 BOMB

.....

Where found: Armory - B2, Canyon, and several other locations

Purpose : Explodes upon remote detonation

Directions : Equip it and press A to set it, and press B to explode it

Other : Only useful for walls and Vulcan Raven's fight. I prefer Claymore way more.

.....

CHAFF GRENADE

.....

Where found: Everywhere.

Purpose : Jam electricty devices. Makes your radar unfunctionable for a while. Security cameras will be unfunctionable also.

Directions : Equip it and press A to throw it. (hold it to throw further)

Other : Good in the Ninja fight and the Tank fight.

.....

CLAYMORE

.....

Where found: Canyon, Snowfield and some other locations

Purpose : Proximity mine.

Directions : Equip it and press A to set.

Other : It knows no friend or foe. You still can get exploded from it. VERY useful in the Vulcan Raven fight! You can also pick up Claymore mines by crawling over them (Canyon).

.....

FA-MAS RIFLE

.....

Where found: Armory - B2, LVL 2 door.

Purpose : MACHINE GUN!!!! WHOO!

Directions : Equip, press A to fire. Hold down B to fire while running.

Other : VERY loud, so be careful! :)

.....

GRENADE

.....

Where found: Everywhere.

Purpose : Uh... a grenade?

Directions : Equip it and press A to throw it. (hold it to throw further)

Other : Only good in the Tank fight.

..

M9

..

Where found: Very Easy - once you begin, it's next to you

Easy - by the lift in the beginning

Normal - Crawl under the truck in the Heliport

Hard - Bomb the upper left wall to reveal a hidden room and M9

Extreme - In the Holding Cells, it is in the air duct on the way to the DARPA chief.

Purpose : Tranquilizer. Will not kill.

Directions : Equip it, press A to fire.

Other : If you don't want to kill, use this. Good for getting better rankings, since kills hurt your rankings.

.....

#### MAGAZINE

.....

Where found: Once you empty a magazine from SOCOM/M9/FA-MAS, you will get one of this.

Purpose : Can be used to distract guards.

Directions : Equip it and press A to throw.

Other : Kinda like the books, it distracts guards for a while.

.....

#### NIKITA

.....

Where found: B1 of Nuke Building.

Purpose : Guided missiles! Yum!

Directions : Press A to fire, then you can control the missile with your control stick.

Other : If you keep it straight, it will gof faster.

.....

#### PSG-1

.....

Where found: Armory - B2, LVL 5 door.

Purpose : Sniper rifle!

Directions : Equip it and you will look through the crosshairs. A is fire, X is zoom out, and B is zoom in.

Other : Use Pentazeim to calm you nerves down for a smoother shot.

.....

#### PSG-T

.....

Where found: Nuke Building B1, LVL 5 door.

Purpose : Tranquilizer rifle.

Directions : Equip it and you will look through the crosshairs. A is fire, X is zoom out, and B is zoom in.

Other : Use Pentazeim to calm you nerves down for a smoother shot.

.....

#### SOCOM

.....

Where found: In the truck in the Helipad.

Purpose : Your standard .45 handgun.

Directions : Equip it, press A to fire.

Other : You can add a suppressor to it to silence its loud fire.

.....

#### STINGER

.....

Where found: By Communications Tower B.

Purpose : Fires Stinger missiles that will follow its locked targets.

Directions : Equip it to view it through its crosshairs and move around to find a spot to lock on and press A to fire.

Other : A must-have for Hind D, useful versus Vulcan Raven. Just TAP R trigger to un-equip so you can move again.

.....

#### STUN GRENADE

.....

Where found: Everywhere.

Purpose : Stuns enemies momentarily.



Directions : Equip it, press A to throw.  
 Other : Can be used against bosses as well.

```

 ()
 | |
 | |
 | |
 | |

 ()
 | |
 | |
 | |
 | |

```

=====

VII. Dog Tags

=====

In Metal Gear Solid: The Twin Snakes, there are numerous Dog Tags to collect from your enemies, as well as one ally. Most of the Dog Tags are easily obtained, but a few can be a real pain to figure out, such as Meryl and the bosses. To snatch an enemies dog tag, sneak up behind, and get real close. When close enough, take out Snake's gun, and hold them at gunpoint. After that, get in first person view and aim at either their head or their testicles. Soon, the enemy will begin to furiously shake, and will give you his dog tag. Next, shoot the enemy in the head, and grab the dog tag.

To get Psycho Mantis and Sniper Wolf's dog tags, frantically shake their bodies after you have defeated them. They will soon drop their dog tags. Vulcan Raven automatically drops his dog tag after he has been annihilated. Liquid Snake's dog tag can be difficult to obtain. During the final battle with him, you must knock him off the top of Metal Gear's head. When he successfully grabs the edge of the head, he will drop his dog tag. To collect Meryl's dog tag, wait until you are about to go into the Commader's Room. Then, shoot her in the head with Snake's M9 tranquilizer gun to knock her unconsciencious. Meryl will forfeit her dog tag following some frantic shaking.

```

 =====
 A) -= Very Easy -=
 =====

```

There are 27 Dog Tags to be collected on the Very Easy difficulty setting.

```

  ~~~~~
  | Dog Tag # | Name | D.O.B. | Blood Type | Location |
  |~~~~~|~~~~~|~~~~~|~~~~~|~~~~~|
  | 000 | Ryan M McCarthy | 0206 | O | Heliport |
  |-----|-----|-----|-----|-----|
  | 001 | Alexandre Ignatoff | 0326 | A | Heliport |
  |-----|-----|-----|-----|-----|
  | 002 | Hyun Sup Kim | 0205 | O | Heliport |
  |-----|-----|-----|-----|-----|
  | 003 | Bruno Petit | 0709 | O | Tank Hangar |
  |-----|-----|-----|-----|-----|
  | 004 | Yuu Shinohara | 0426 | O | Tank Hangar |
  |-----|-----|-----|-----|-----|
  | 005 | Hector S Garcia | 1208 | N/A | Tank Hangar |
  |-----|-----|-----|-----|-----|
  | 006 | Young Chan Park | 1122 | B | Armory |
  |-----|-----|-----|-----|-----|
  | 007 | Rathana Danh Sang | 0827 | N/A | Armory |
  |-----|-----|-----|-----|-----|
  | 008 | Scott Derby | 0522 | B | Canyon |
  |-----|-----|-----|-----|-----|
  
```



|     |                       |      |     |                  |
|-----|-----------------------|------|-----|------------------|
| 006 | Kevin Leun            | 0517 | N/A | Armory           |
| 007 | David Falcon Marrero  | 0511 | AB  | Armory           |
| 008 | Elran Joseph Ettinger | 0822 | O   | Armory           |
| 009 | Miguel Barrierio      | 0623 | A   | Canyon           |
| 010 | Jan Olbrich           | 0811 | N/A | Canyon           |
| 011 | Alistair Kan          | 0524 | B   | Canyon           |
| 012 | Benjamin T Turner     | 0520 | O   | Nuke Building B1 |
| 013 | Hank Van Den Brink    | 0913 | N/A | Nuke Building B1 |
| 014 | Daijyu Satu           | 0821 | B   | Blast Furnace    |
| 015 | Ryan G Vicera         | 0304 | O   | Blast Furnace    |
| 016 | Diogo M Fernandes     | 1010 | O   | Warehouse        |
| 017 | John D Eriani         | 1107 | N/A | Warehouse        |
| 018 | Chris Kohler          | 0418 | O   | Warehouse North  |
| 019 | Pat RW Hart           | 0806 | O   | Warehouse North  |
| 020 | Matt Davies           | 0422 | N/A | Underground Base |
| 021 | Aurore Portet         | 0909 | N/A | Underground Base |
| 022 | Johnny Sasaki         | N/A  | N/A | Nuke Building B1 |
| 023 | Meryl Silverburgh     | N/A  | N/A | Nuke Building B1 |
| 024 | Psycho Mantis         | N/A  | N/A | Commader Room    |
| 025 | Sniper Wolf           | N/A  | N/A | Snowfield        |
| 026 | Vulcan Raven          | N/A  | N/A | Warehouse        |
| 027 | Liquid Snake          | N/A  | N/A | Escape Route     |

\*\*\*\*\*

=====  
C) == Normal ==  
=====

There are 29 Dog Tags to be collected on the Normal difficulty setting.

\*\*\*\*\*

| Dog Tag # | Name             | D.O.B. | Blood Type | Location |
|-----------|------------------|--------|------------|----------|
| 000       | Michael P. Janes | 0317   | O          | Heliport |
| 001       | Paul Rogozinski  | 1001   | B          | Heliport |

|     |                           |      |     |                  |
|-----|---------------------------|------|-----|------------------|
| 002 | Rich Barnes               | 0920 | A   | Heliport         |
| 003 | Kalle Seponpoika Viitanen | 0627 | A   | Tank Hangar      |
| 004 | Dan Amadio                | 0714 | A   | Tank Hangar      |
| 005 | Kate Dyson                | 0221 | AB  | Tank Hangar      |
| 006 | Kaleb T Heil              | 0714 | AB  | Armory           |
| 007 | Kevin Gordon              | 0320 | A   | Armory           |
| 008 | Carlos A Ortega           | 1004 | O   | Armory           |
| 009 | Edward A Holmberg         | 0705 | A   | Canyon           |
| 010 | Suneel C Buggal           | 1229 | N/A | Canyon           |
| 011 | Ken Alguire               | 1014 | O   | Canyon           |
| 012 | David Miner               | 1206 | N/A | Nuke Building B1 |
| 013 | Steven Tieu               | 0130 | N/A | Nuke Building B1 |
| 014 | Souta Akaka               | 0803 | O   | Blast Furnace    |
| 015 | Paul Caporicci            | 0113 | O   | Blast Furnace    |
| 016 | Akitaka Tosaka            | 1118 | O   | Warehouse        |
| 017 | Carey Murray              | 0731 | O   | Warehouse        |
| 018 | Brian L Hansen            | 1129 | A   | Warehouse        |
| 019 | Eric Dechaux              | 0312 | AB  | Warehouse North  |
| 020 | Essam Khilil L Obaldi     | 0722 | AB  | Warehouse North  |
| 021 | Vong Chan Phuc            | 0603 | N/A | Underground Base |
| 022 | Patrick Ingoldsby         | 0506 | A   | Underground Base |
| 023 | Johnny Sasaki             | N/A  | N/A | Nuke Building B1 |
| 024 | Meryl Silverburgh         | N/A  | N/A | Nuke Building B1 |
| 025 | Psycho Mantis             | N/A  | N/A | Commader Room    |
| 026 | Sniper Wolf               | N/A  | N/A | Snowfield        |
| 027 | Vulcan Raven              | N/A  | N/A | Warehouse        |
| 028 | Liquid Snake              | N/A  | N/A | Escape Route     |

\*\*\*\*\*

=====

There are 33 Dog Tags to be collected on the Hard difficulty setting.

```

*****
| Dog Tag # | Name | D.O.B. | Blood Type | Location |
|*****|*****|*****|*****|*****|
| 000 | Mark Ernest Torio | 1014 | B | Heliport |
|-----|-----|-----|-----|-----|
| 001 | Alex H Higgins | 1206 | O | Heliport |
|-----|-----|-----|-----|-----|
| 002 | Li Shi Dan | 0814 | A | Heliport |
|-----|-----|-----|-----|-----|
| 003 | Kristopher Schmitt | 1224 | O | Tank Hangar |
|-----|-----|-----|-----|-----|
| 004 | Arthur Manual Szpilski | 0409 | A | Tank Hangar |
|-----|-----|-----|-----|-----|
| 005 | Kevin S Weng | 0316 | O | Tank Hangar |
|-----|-----|-----|-----|-----|
| 006 | Michael A Williams | 1229 | O | Armory |
|-----|-----|-----|-----|-----|
| 007 | Patrick M Michailishyn | 0917 | O | Armory |
|-----|-----|-----|-----|-----|
| 008 | Julliard Ej Emilein | 1019 | N/A | Armory |
|-----|-----|-----|-----|-----|
| 009 | Ross Lillo | 0529 | O | Armory |
|-----|-----|-----|-----|-----|
| 010 | Andy E Turner | 1022 | N/A | Canyon |
|-----|-----|-----|-----|-----|
| 011 | Nouri Frederic | 0309 | A | Canyon |
|-----|-----|-----|-----|-----|
| 012 | Eric J Holmes | 0605 | N/A | Canyon |
|-----|-----|-----|-----|-----|
| 013 | Alex G Fisico | 1121 | O | Canyon |
|-----|-----|-----|-----|-----|
| 014 | Jong Dong Kim | 1208 | A | Nuke Building B1 |
|-----|-----|-----|-----|-----|
| 015 | Navid Masserrat | 1210 | AB | Nuke Building B1 |
|-----|-----|-----|-----|-----|
| 016 | Jad V Jureidini | 0824 | O | Blast Furnace |
|-----|-----|-----|-----|-----|
| 017 | John Michael V Lim | 0217 | O | Blast Furnace |
|-----|-----|-----|-----|-----|
| 018 | Andrew M Long | 0727 | O | Blast Furnace |
|-----|-----|-----|-----|-----|
| 019 | Bruno Almeida Vilares | 0324 | O | Warehouse |
|-----|-----|-----|-----|-----|
| 020 | Dmitriy Sergeevitch | 0121 | AB | Warehouse |
| | Kovalev | | | |
|-----|-----|-----|-----|-----|
| 021 | Oscar M Grandell | 0303 | N/A | Warehouse |
|-----|-----|-----|-----|-----|
| 022 | Frenando Makio | 0131 | O | Warehouse North |
| | Yoshimoto | | | |
|-----|-----|-----|-----|-----|
| 023 | Christopher J Barbour | 0924 | A | Warehouse North |
|-----|-----|-----|-----|-----|
| 024 | Jose Mario Castillo | 0905 | A | Underground Base |
| | Secilla | | | |

```



|     |                       |      |     |                  |
|-----|-----------------------|------|-----|------------------|
| 016 | James O'Reilly        | 1017 | N/A | Nuke Building B1 |
| 017 | Tomotaka Morita       | 0903 | B   | Blast Furnace    |
| 018 | John H Weaver         | 0607 | A   | Blast Furnace    |
| 019 | Jaeho Song            | 1129 | O   | Blast Furnace    |
| 020 | Todd Macintyre        | 1020 | N/A | Blast Furnace    |
| 021 | Mike Liseman          | 0905 | O   | Warehouse        |
| 022 | Wal K Lam             | 0826 | B   | Warehouse        |
| 023 | Kenichi Rou Kudo      | 0604 | B   | Warehouse        |
| 024 | Inhyuk Lim            | 0116 | B   | Warehouse        |
| 025 | Eric Gatinaeu         | 0619 | A   | Warehouse North  |
| 026 | Brad Furminger        | 1123 | AB  | Warehouse North  |
| 027 | Theo Colin Tyler King | 1115 | A   | Underground Base |
| 028 | Robert G Pring        | 0630 | O   | Underground Base |
| 029 | Jun Yo Kim            | 0514 | B   | Underground Base |
| 030 | Paris Alexandre       | 0828 | A   | Underground Base |
| 031 | Johnny Sasaki         | N/A  | N/A | Nuke Building B1 |
| 032 | Meryl Silverburgh     | N/A  | N/A | Nuke Building B1 |
| 033 | Psycho Mantis         | N/A  | N/A | Commader Room    |
| 034 | Sniper Wolf           | N/A  | N/A | Snowfield        |
| 035 | Vulcan Raven          | N/A  | N/A | Warehouse        |
| 036 | Liquid Snake          | N/A  | N/A | Escape Route     |

\*\*\*\*\*

( ) ( )

=====

VIII. Bosses

=====

| |

=====

A) == Boss Fight #1 - Revolver Ocelot ==

=====

Quit that gun-swirling, Communist. This comrade can be quite easy or quite hard, depending how swift you can manuever your protangist. Your weapon of

choice has to be SOCOM. Now, run around the plate in circles early on, in hope of getting a good shot at Revolver. Fire your SOCOM at him, and if he gets hit, he will stop because of recoil. Keep going at him, but don't fire again until he starts moving again. That way, you have an excellent head start on hitting him on the next turn. Keep doing that, but this time, you have to TAP R1 LIGHTLY TWICE to reload your SOCOM. If you don't do that, you will have to waste precious seconds reloading while Ocelot runs away from your grasp. And you will have start over again.

Ocelot's pistol is able to reflect off walls to hit you, so be prepared for some outrageous hits. Still, keep going after him for a good, clean shot at him. You could want to out-wit him by going the opposite direction in a heartbeat to catch him going at you.

=====  
B)                                    -- Boss Fight #2 - Tank --  
=====

Your main weapon here is definitely the Grenades, but your main asset to surviving this battle is the Chaff Grenades, since it temporarily disables the cannon of the tank (as controlled by Vulcan Raven). Throw a Chaff Grenades before moving and wait for it to start working. Then move out of the rock you're behind and head for the tank. Equip your Grenades and go around the tank in circles (avoid its cannon and the gunner!). When you think you're not targeted by either of the guns, stop and turn your body toward the gunner in the middle and throw a Grenade toward him. If it's a bull-eye, a brief scene will show a Grenade landing onto the Gunner's lap. Soon after, the Grenade will explode and inflict damage to 2/5 of the Gunner's health. Big money, baby! However, if it was not a bull-eye but pretty close to the Gunner, it will do about 1/5 of the damage. After each hit, the Gunner will return to the tank to tend care of itself. Therefore, don't throw a barrage of Grenades after he is hit... wait for him to get back up and resume your throwing.

There are two Gunners in all, so don't think you've won when the health bar goes down! Since the battle can be drawn-out, there are items in the far north/northeastern border. Also, there are several items in the trench to the north.

Also, there is a way to stop the Tank from moving - place a Claymore or C4 or Grenade or whatever near a tank. If it explodes near a wheel, it will destroy the wheel. If enough of them are disabled, the tank will stop moving. It will make your battle MUCH easier.

Keep moving in circles and you shall be the victor!

=====  
C)                                    -- Boss Fight #3 - Cyborg Ninja --  
=====

There are several stages here - I will divide them up into parts, in order of course.

Stage 1 - Ninja will wield his sword, but do no fear. Un-equip your firearms fists to damage him. Don't believe me? Go ahead and try to hit him with your guns, any of them. It won't work. :) After two combos, Ninja will say "only a fool trusts his life on a weapon" and discards his sword.



Stage 2 - Ninja will be at his toughest here. He starts using his legs to kick you around. You have to counter him after he misses. Keep your distance and move around to make him miss his spin kick, and strike back with your hand/kick combo. He will occasionally jump up in the air and stomp onto the ground. Just move out of the way and hit him when he stomps. When his health reaches half of the bar, Ninja cheats.

Stage 3 - Ninja will play hide-and-seek with you with his stealth. Bah. Just look around for a tiny hint of his stealth (can see a discolor from his stealth) and go up to him and hit him around. He won't even hit you back if you're quick enough. His hiding places are the corners, the place in the middle (offices), and the path between the offices and the machinery to the north. After three hits, he will stop cheating and becomes seen once again.

Stage 4 - The easiest. Ninja will become sluggish and try to punch you once per time. However, he will 'warp' to try to catch you by surprise. Just keep MOVING until you KNOW you have seen him punch. Then, go up to him and do your usual combo. When low in health, Ninja will 'warp' TWICE or even THRICE, so be careful. It will remain this way until his health bar is 100% gone.

=====  
D)                                    -- Boss Fight #4 - Psycho Mantis ==  
=====

First, Mantis will take over Meryl's body. Quickly un-equip anything and punch her three time to knock her out. Psycho Mantis becomes frustrated and begins reading into your mind and does some tricks with your controller. Now the real thing begins.

Psycho Mantis will read your every move and avoid all of your attacks (except rare, lucky FA-MAS sweeps, but it is RARE!). Now, the trick here is to switch your controller to ANOTHER socket! So, your controller should be in socket 1, but move it to 2 or 3 or 4. It will stop Psycho Mantis from reading your moves UNTIL he moves into your body (collide into each other) and he will find out your secret and you will have to change sockets again.

Now, about attacking... it is very simple, basic things. Just mow him down with SOCOM or FA-MAS (if you got it in the Armory). If your SOCOM bullets runs out, you can find some more in the NE corner, behind a statue. Mantis will throw some pictures, statues, and such at you. When it happens, just crawl down and all of the objects will go over you. Then get back up and continue looking for him and shooting at him. After 2/3 of his HP has been deleted, he will start using Meryl as a hostage again. Just punch her out like you did before and she should be fine.

Later, Mantis will start throwing some 'fireballs' at you, just run around in circles and hope you find him and shoot him. When he has about 1/5 HP left, he will revert to the 'throw some crap around' method. You know what to do. Good luck, my friend.

=====  
E)                                    -- Boss Fight #5 - Sniper Wolf ==  
=====

Sniper Wolf lies on the second tower of the Communication Tower in the far

end of the Passage. First, grab the items around the square by the door by hugging the walls. Now that you have enough pentazemin, use a pill (select it on the Item Menu and press A) and go to either corner in the rear and move a bit toward the door. Now, face north and equip your PSG-1.

You have to be very quick with your PSG-1. Look up toward the second floor and try to find Sniper Wolf seeking for you. Hold down B to zoom in, and aim for her, any part of the body and nail her before she hits you! She is quick to shoot once she finds you. You'll know if she finds you when you see an '!' over her head. She will hide behind a post, so when it happens, aim either the the left or right of the post. If you're lucky, she will go out in that way, giving you a head start on her! Whoo! Keep following her and don't lose her.

When you are hit, you flinch, causing the rifle to lose its intended position... therefore, when that happens, just un-equip it and move to a different position (force Sniper Wolf to look for you more) and re-equip it and start again. Also, if your rifle jerks around a little, that means your Pentazemin pill have expired. Take one more and continue. (There are some pills in the SW corner here, if needed).

Don't lose Wolf and do try to hit her when she's running... it is possible to hit her that way. Head shots will cause twice the normal damage! Good luck...

=====  
F)                                    --= Boss Fight #6 - Hind D =-  
=====

If you stay between the exit from the Communications Tower to the roof top and the large fuel tanks, then this will cut down on the damage received by Snake from Liquid's gunfire. However, there is a downside to this, which is the helicopter becomes more difficult to hit. Beside the Communications Tower B entrance/exit is a Ration. Between the tanks and the edge of the tower, in the large clearing, is a set of missiles for your Stinger. You must equip your Stinger missile launcher. This is the only weapon that will penetrate the Hind D. When it is equipped, you will be placed in first person view of the surrounding area.

To discover the location of Liquid and his Hind when the get out of site, look at Snake's radar. On the radar is a large, red bar displaying the location of the helicopter. Always have Solid Snake viewing the red bar on the radar. Liquid does not always have his helicopter at eye level, so if you have Snake facing the bar, but you do not see the Hind, the look up and down until your Stinger starts to target the helicopter with three boxes.

Aim the Stinger missile launcher at the Hind D. When at least one of the boxes turn from green to red, fire the missile. This usually causes the missile to home towards the helicopter. You are usually able to tell if a missile will hit or miss, because of the beeping it makes when it is on target after being released. After each triumphant hit with the Stinger, Liquid will reply with a short, but abundant rapid fire from the guns hanging out of the Hind D. Once you have successfully hit the helicopter around seven times, Liquid will shoot a missile towards the roof top. Snake does not have anything to worry about since the missile hits where the staircase is located at.

Following the missile launched by Liquid, he will start to control his Hind D below the roof top, making it impossible for Solid Snake to hit. This is when you must be patient, and keep the helicopter in sight. Wait until Liquid raises the helicopter, then shoot at it. Once you have depleted all of the

health, or armor, for the Hind D, Liquid Snake will shoot one final missile at the roof top. This time the missiles lands between the two tanks, and the edge of the roof. More specifically, where the spare Stinger missiles were located.

=====  
G)                    --= Boss Fight #7 - Sniper Wolf (Pt. 2) ==  
=====

This boss fight is easy to win once you have located Sniper Wolf. If you happen to run out of ammo, there are bullets for the PSG1 on the right side of the Snowfield area, and PSG1-T bullets on the left side.

Sniper Wolf will run back and forth, and hide behind the trees that are on the otherside of the Snowfield area. The easiest way I found to discover where she is without getting hit is to stand on the right side of the tree that is on the left end of the snowfield. If Snake is under the tree, it makes it difficult for her to spot him.

While under the tree, wait until you see a red laser beam being pointed at Snake. When this happens, face in the direction of the laser, and equip your sniper rifle, either the PSG1 or the PSG1-T. After the sniper rifle is equipped, you should have Sniper Wolf in your cross hairs. Shoot her, and follow where she went by using the scope of your sniper rifle. If she goes behind a tree, then aim at the middle of the tree and wait until she steps out. At the moment she steps out from behind it, place your cross hairs on her, and pull the trigger. If you are not quick enough, she will shoot Snake before he has a chance to get trigger happy. Also, don't forget to use the Pentazemin pills to steady Snake's shaking.

The best time to shoot Sniper Wolf is when she is running from tree to tree. This leaves an open shot to her body for you. If you are wanting to shoot her in the head, then wait until she tries to aim her rifle at Snake. While having the sniper rifle equipped, if you see a red beam flash in front of Snake, you should know that Sniper Wolf is aiming at Snake, attempting to get the perfect kill shot. If and when she does do this, you have two options. To unequip Snake's rifle and run to cover, or quickly find her in the scope and blast her with a bullet. If Snake is ever shot while having the rifle equipped, you will have to unequip the sniper rifle, then re-equip it.

=====  
H)                    --= Boss Fight #8 - Vulcan Raven ==  
=====

At the beginning of this brawl, Vulcan Raven moves around slowly, stops at corners, and shoots his gatling gun. Equip your Nikita missile launcher, and closely follow behind Vulcan Raven. When he stops, shoot a Nikita, and guide it into his back. You must shoot Raven from the back, or he will shoot the missile down. Also, do not follow too closely or Vulcan will turn around and shoot Snake. Make sure that when you shoot the missile launcher at him, Snake is around the corner of the same box.

After a few hits by the Nikita gets Vulcan pacing around faster, and only stopping to shoot when he spots Snake. It becomes difficult to hit Vulcan once he begins this procedure, so that means it is time for a new strategy on your behalf. Place claymore mines at intersections of the boxes and wait for Vulcan to step on them. If you happen to run out of Claymores, or you just didn't have any to start with, there is a box of them on the end where the boxes fall and block the passage way. These will regenerate from time to time.

Also in the room is a ration on the otherside from where the Claymore mines can be found at.

=====  
I)                                == Boss Fight #9 - Metal Gear Rex ==  
=====

This fight can be long and tedious if you do not know where to attack Metal Gear at. Right after the battle starts, if you call Otacon, he tells you that Metal Gear's weakness is the Radome, which is the large circular object on Metal Gear's left arm. If Snake destroys this, then the top hatch will be exposed, revealing Liquid Snake inside. When the pilot seat opens, Snake must shoot into the cockpit where Liquid is to destroy Metal Gear Rex.

The only way that Snake will cause damage to Metal Gear is by using the Stinger Missile launcher. During the first stage, aim at the radome on the left arm of Metal Gear. Pull the trigger when the box surrounding the radome becomes red. Do the same thing throughout the second part, but aim at the cockpit instead of the radome, which will not exist. Keep your rations equipped throughout the entire battle.

There are a few different attacks used by Metal Gear. It will try to stomp on Snake, instantly killing him, when he gets extremely close. Another short range attack is using the laser that seems to be shooting out of the crotch of the beastly hunk of metal. Metal Gear also uses a machine gun attack when Snake is too far away for the Laser attack to be used. The final attack performed by the pile of machinery is a bombing attack. Metal Gear will launch three missiles in the direction Snake is in when Snake is nearly out of viewing range of Metal Gear.

Once Metal Gear receives so many blows to the radome, an FMV will start. When Liquid is about to take the life of Solid Snake, he is saved by a neutral acquaintance, known as Gray Fox. After a few more sequences have completed, you will regain control of Snake. Gray Fox is shouting to you to shoot the Stinger, and take his own life. Continously press the fire, A, button to blow the Cyborg Ninja to hell. Hold on a sec...Snake is chickening out. He doesn't want to kill Gray Fox. After a while of contemplating, Liquid decides to take the life of Gray Fox, instead of waiting for his brother to finish the job.

Now at the stern of Metal Gear, controlling every movement of the large nuclear machine, is Liquid Snake. The cockpit is now open, free for Snake to destroy Metal Gear with more Stinger missiles. Liquid will use the same attacks that Rex done automatically in the first half of the battle. This time around, Snake needs to aim at the cockpit. Other than that, there is nothing new about the fight that was not discovered in the first portion.

=====  
J)                                == Boss Fight #10 - Liquid Snake ==  
=====

This boss fight is a straight up brawl between two cloned brothers. Snake will not be equipped with any weapons or items in this battle. The only way to defeat his brother, Liquid, is by his fist. However, you must hurry up in this battle because the place is about to be bombarded by a nuclear strike. You will have three minutes to control Solid Snake to a triumphant victory over Liquid Snake.

When you attack, do not try to connect with a combo attack, unless you hit Liquid with the first punch. If not, then you may not hit Liquid with the combo, leaving Solid Snake wide open for an attack by Liquid. There are a few different attacks performed by Liquid. He will charge at Snake during the final moments of the battle. Throughout the rest of the battle, Liquid will deliver a combination of punches and combos to Snake.

If Snake knocks Liquid off the ledge of Metal Gear's head, where is is barely haning on, Liquid will drop his dog tag, allowing Snake the opportunity to capture it. If Liquid knocks Snake off the edge of Metal Gear, then just pull yourself back on to the top of the head.

```
-----
(  _  _ )                                     (  _  _ )
|  |                                         |  |
|  |                                         |  |
|  |                                         |  |
|  |                                         |  |
-----
IX. Ghost Pictures
-----
|  |                                         |  |
|  |                                         |  |
|  |                                         |  |
|  |                                         |  |
|  |                                         |  |
-----
```

This section is not yet completed. Sorry!

```
-----
(  _  _ )                                     (  _  _ )
|  |                                         |  |
|  |                                         |  |
|  |                                         |  |
|  |                                         |  |
-----
X. Endings
-----
|  |                                         |  |
|  |                                         |  |
|  |                                         |  |
|  |                                         |  |
|  |                                         |  |
-----
```

```
=====
A)                                     -= Meryl's Ending -=
=====
```

Oh...how sweet they are together! If you did not give up during the torture dished out by the one handed ace, Revolver Ocelot, this will be the ending that starts from the defeat of Liquid Snake on Metal Gear Rex's head. In Meryl's Ending, Meryl survived everything she went through. Now, Solid Snake and she must escape together, before the entire joint blows up.

After your jeep exits the base, and Liquid's does also, each is involved in a near fatal accident. It seems as if Liquid is about to kill Solid when the FoxDie virus sets in, and eliminates Solid Snake's twin brother. Then, Meryl and Snake walk down the ledge of a mountain, and discover a snowmobile at the bottom. Meryl hands Snake a Bandana, and they ride off in the sunset.

```
=====
B)                                     -= Otacon's Ending -=
=====
```

If Snake was unable to tolerate the pain delivered during the torture stage of the game, his love will have already been dead by the time Snake overcomes his twin brother for the seemingly final time. Ocelot appears, and you two escape the complex together.





